

Manual del Usuario

User Manual

Benutzerhandbuch

Manuel de l'utilisateur

Manuale D'Uso

Manual do Usuario



TRAULIFT PREMIUM SERIES

Gracias por adquirir la nueva serie de elevadores "Videolift Premium Series".
Los nuevos elevadores de la serie Premium son más robustos, estables y sencillos de montar.
Se suministra con todos los componentes necesarios para la instalación de cualquier aplicación audiovisual estándar. (nota: tal aplicación no debe exceder la capacidad máxima de peso de la unidad, 19Kg).
Los modelos disponibles son: VL-100PR y VL-200PR.

Thank you for purchasing the new "Video Lift Premium Series"
The new Premium series lifts are more robust, stable and easy to assemble.
It's supplied with all necessary components for installation in any standard audiovisual application.
(Such application should not exceed the maximum weight allowed of the unit, 19Kg).
The new available models are: VL-100PR and VL-200PR

Wir danken Ihnen, dass Sie die neue Serie von Hebevorrichtungen "Videolift Premium Series" gekauft haben. Die neuen Hebevorrichtungen der Serie Premium sind robuster, stabiler und können leichter montiert werden.
Sie werden mit allen Komponenten geliefert, die für die Installation jeder audiovisuellen Standardanwendung erforderlich sind (Anmerkung: Diese Anwendung darf die maximale Belastungsfähigkeit der Einheit (19 kg) nicht überschreiten).
Folgende Modelle stehen zur Verfügung: VL-100PR und VL-200PR.

Merci pour acquérir la nouvelle série d'ascenseurs "Videolift Premium Series".
Les nouveaux ascenseurs de la série Premium sont plus robustes, plus stables et faciles à monter.
Ils sont fournis avec tous les éléments nécessaires à l'installation de quelque application audiovisuelle standard. (nota: cette application ne doit dépasser la capacité maximale du poids de l'unité, 19Kg).
Ils sont disponibles dans les modèles VL-100PR et VL-200PR.

La ringraziamo per aver acquistato la nuova serie di elevatori "Videolift Premium Series".
I nuovi elevatori della serie Premium sono più robusti, stabili e semplici da montare.
In dotazione sono inclusi tutti i componenti necessari per l'installazione di qualsiasi applicazione audiovisiva standard. (nota: l'applicazione non deve eccedere la capacità di peso massima dell'unità, 19 kg).
I modelli disponibili sono: VL-100PR e VL-200PR.

Obrigado por adquirir o novo "Video Lift Premium Series"
A nova série de Lift Premium é mais robusta, estável e fácil de montar.
É vendido com todos os componentes necessários para uma fácil instalação audiovisual Padrão.
(Importante: Esta aplicação não deve exceder a capacidade máxima de peso da unidade, 19 kg)
Os modelos disponíveis são: VL-100PR e VL-200PR

1



1. Lea las instrucciones completamente antes de instalar
2. Videolift solo debe ser instalado por personal cualificado.
3. Videolift solo debe ser instalado en interiores.
4. Debe estar situado lejos de sustancias inflamables y lejos del agua.
5. No obstruir el recorrido de trabajo con las manos o cualquier objeto.
6. La parte más baja del aparato debe estar situado a una distancia mínima del suelo de al menos 2,50 m.
7. La unidad trabaja solo a 230V AC.
8. La posición de trabajo de videolift es horizontal, con la placa multitaladro hacia abajo y debe estar perfectamente nivelado. No instalar en lugares inestables.
9. Todas las conexiones eléctricas, deben realizarse desconectados de la tensión.
10. Videolift está diseñado para poner el proyector suspendido, no alojar el mismo en el interior del mecanismo (ver sección:"instalar el proyector").

2



1. Read the instructions before installing
2. Video Lift must be installed by qualified personnel
3. Video Lift must be installed indoors.
4. It should be situated away from flammable substances and water.
5. Do not obstruct the travel distance with your hands or any object.
6. The apparatus lower part must be located a minimum distance from the floor of at least 2.50 m.
7. The equipment only work on 230W
8. The Video Lift works on horizontal position with multi drill plate face down and must be perfectly level. Do not install in places unstable.
9. All electrical connections must be switched off
10. Video Lift is designed to works the projector suspended, do not accommodate it inside the mechanism (see section "installing the projector")



1. Lesen Sie vor dem Installieren die Anweisungen gründlich durch.
2. Videolift darf nur von qualifiziertem Personal installiert werden.
3. Videolift darf nur in Innenräumen installiert werden.
4. Die Vorrichtung muss weit weg von brennbaren Stoffen und Wasser aufgestellt werden.
5. Die Bewegungen des Apparats nicht behindern – Vorsicht mit den Händen und sonstigen Gegenständen.
6. Der unterste Teil des Apparats muss mindestens 2,50 m vom Boden entfernt sein.
7. Der Apparat arbeitet nur mit 230V AC.
8. Videolift arbeitet in einer horizontalen Stellung, mit der Lochplatte nach unten, und muss perfekt nivelliert sein. Nicht an unstablen Stellen aufstellen.
9. Beim Realisieren der elektrischen Anschlüsse müssen sie zuerst alle spannungslos gestellt werden.
10. Videolift ist so entworfen, dass der Projektor aufgehängt werden kann; letzteren nicht im Inneren des Mechanismus installieren (siehe Abschnitt: „Installation des Projektors“).



1. Lire attentivement toutes les instructions avant de réaliser l'installation
2. Videolift doit être installé uniquement par du personnel qualifié.
3. Videolift doit être installé uniquement en intérieurs.
4. Il doit être tenu loin de substances inflammables et loin de l'eau.
5. Ne pas entraver le parcours de travail avec les mains ou tout objet.
6. La partie la plus basse de l'appareil doit être située à une distance minimale du sol de 2,50 m.
7. L'unité travaille uniquement à 230V c.a.
8. La position de travail de Videolift est horizontale, la plaque multi-trous étant située ver le bas. Il doit être parfaitement nivelé. Ne pas installer sur des sols instables.
9. Toutes les connexions électriques doivent être réalisées hors tension.
10. Videolift a été conçu pour y suspendre le projecteur, ne pas loger celui-ci à l'intérieur du mécanisme (voir section : « Installation du projecteur »)



1. Leggere le istruzioni completamente prima di procedere all'installazione.
2. L'installazione di Videolift deve essere eseguita solo da personale qualificato.
3. Installare Videolift sono in ambienti chiusi.
4. Mantenere lontano da sostanze infiammabili e dall'acqua.
5. Non ostruire il percorso di lavoro con le mani o altri oggetti.
6. La parte più bassa dell'apparecchio deve essere posizionata a una distanza minima dal pavimento di almeno 2,50 m.
7. L'unità funziona solo a 230 V AC.
8. La posizione di lavoro di Videolift è di tipo orizzontale, con la piastra di fissaggio forata rivolta verso il basso. L'unità deve risultare perfettamente livellata. Non installare su superfici instabili.
9. Effettuare tutti i collegamenti elettrici mantenendo l'unità scollegata dalla rete elettrica.
10. Videolift è progettato per tenere il proiettore sospeso, non collocare lo stesso all'interno del meccanismo (vedere "Installazione del proiettore").

3



1. Leia as instruções completamente antes de iniciar a instalação.
2. Vídeolift deve ser instalado por um Profissional qualificado.
3. Vídeolift só deve ser instalado em lugares interiores.
4. Manter longe do alcance de substâncias inflamáveis e longe da água.
5. Não obstruir o movimento de trabalho do Vídeolift com as mãos ou qualquer outro objeto.
6. A parte mais baixa do aparelho deve estar situada a uma distância mínima de 2,50m do chão.
7. A unidade trabalha somente a 230 v AC
8. A posição de trabalho do Vídeolift é horizontal, com a placa perfurada voltada para baixo e deve estar perfeitamente nivelado. Não instalar em locais instáveis.
9. Todas as conexões elétricas, devem ser realizadas com a eletricidade desligada.
10. Vídeolift está desenhado para trabalhar com o projetor suspenso, não colocar no mesmo interior do mecanismo. (ver seção "instalar projetor").

1 Comprobar el contenido del paquete / Check the contents of the package / Den Inhalt des Pakets überprüfen / Vérifiez le contenu de l'emballage / Verificare el contenuto del pacco / Comprovar o conteúdo do pacote

1 x CEILING BRACKET



1 x VIDEOLIFT

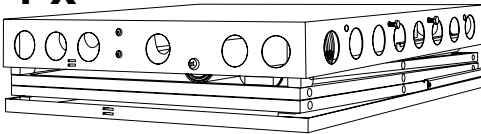

4 x PROJECTOR BRACKET



4

4 x CLOSE COLUMN "A"

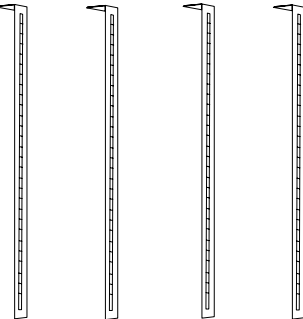

4 x CLOSE COLUMN "B"



1 x CLOSE CAP



4 x SPRING

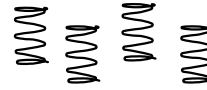

4 x DIN 7985 - M6x16



4 x DIN 7985 - M4x12



4 x DIN 965 - M4x50



4 x DIN 985 - M4



4 x DIN 934 - M4



4 x DIN 125 - M4



4 x DIN 125 - M6



4 x DIN 6798 J - M4



1 x ALLEN



2 Fijar el "ceiling bracket" / Fix the "ceiling bracket" / Fixieren der "ceiling bracket" / Fixer les "ceiling bracket" / Fissare il "ceiling bracket" / fixar o "ceiling bracket".

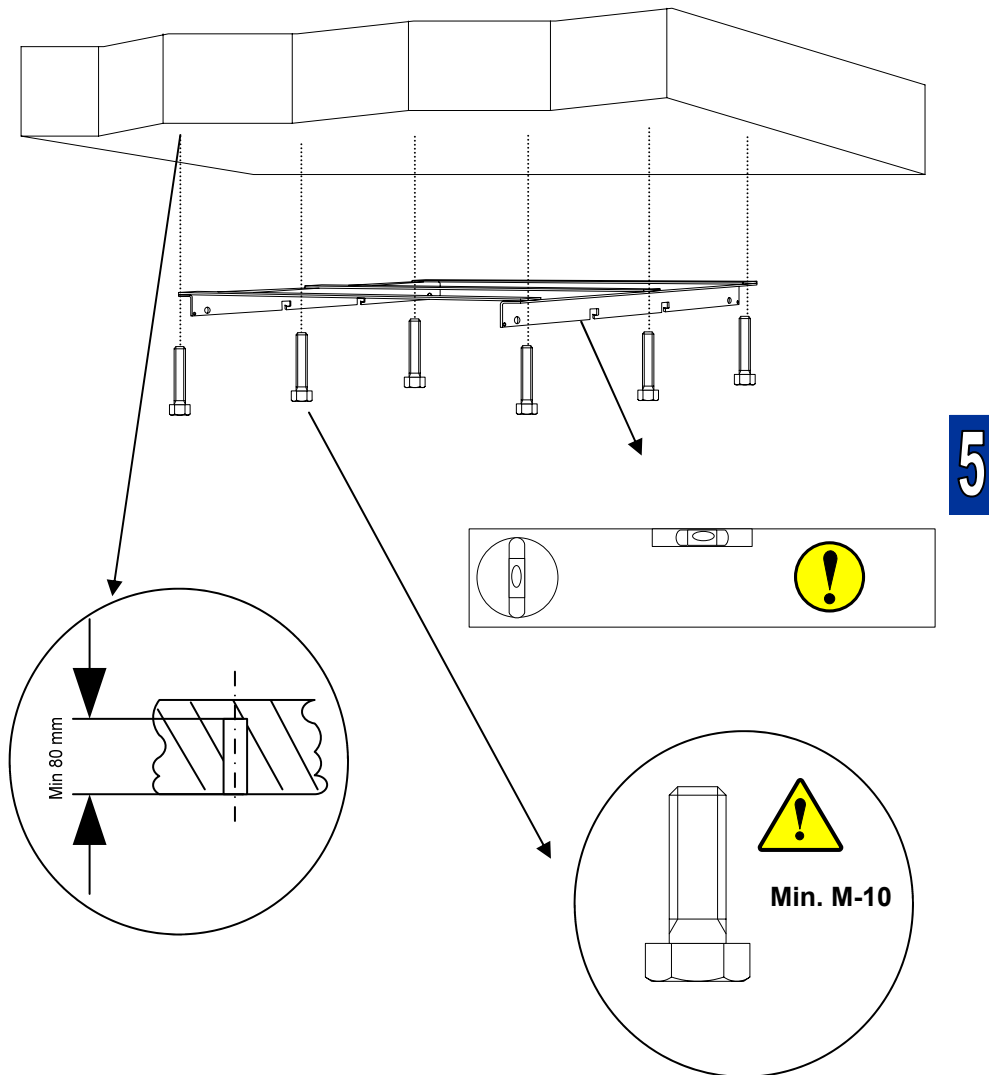

Instalación - installation - installation - installation - installazione - instalação

3 Acoplar el "videolift" / Attach the "videolift" / Befestigen Sie die "videolift" / Joindre les "videolift" / Allegare il "videolift" / anexar o "videolift".

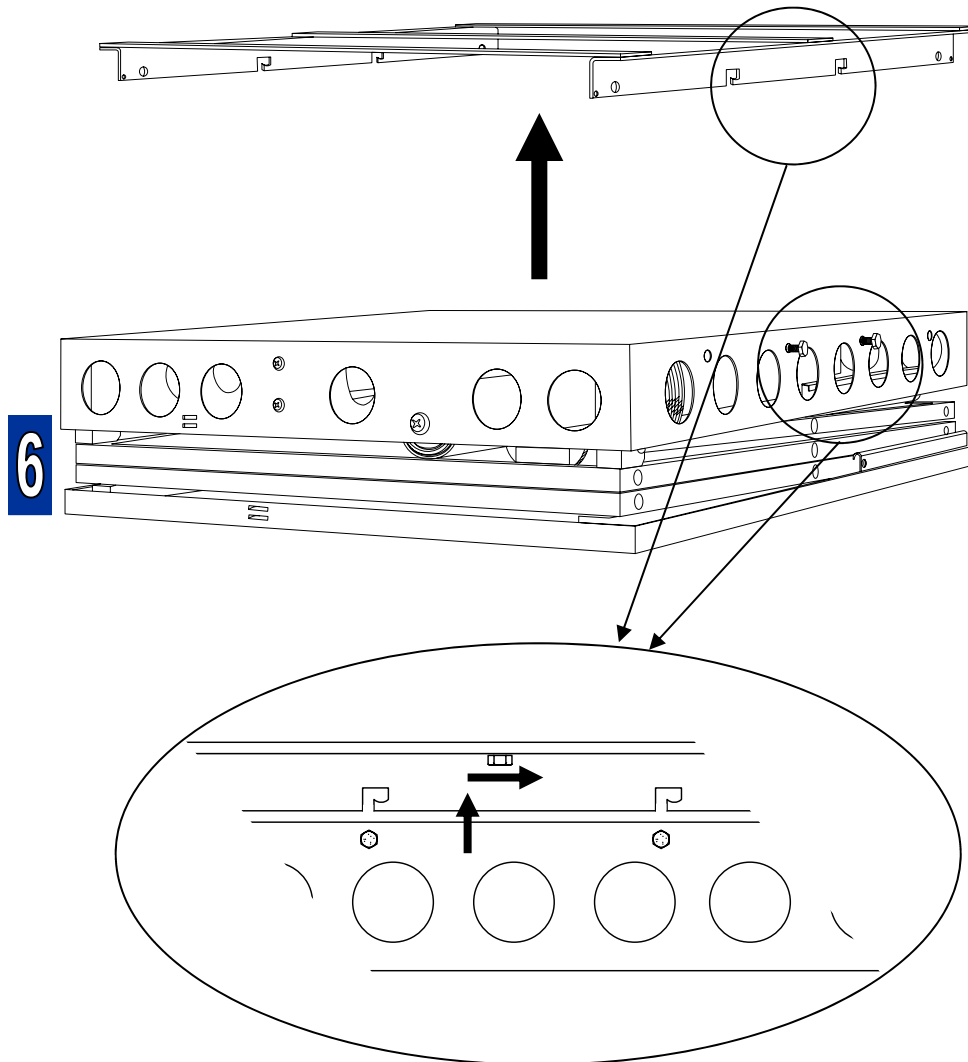

TRAULIFT Premium Series

4 Ajustar los tornillos (8u) / Adjusting screws (8u) / Stellschrauben (8u) / Vis de réglage (8u) / Viti di regolazione (8u) / Ajustando o parafusos (8u).

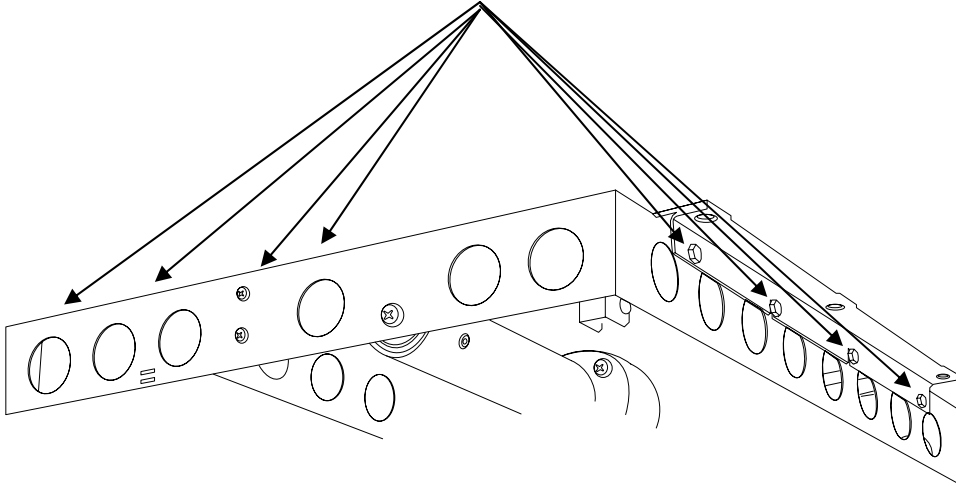

5 Atornillar los "projector bracket" / Screw the "projector bracket" / Schraube der "projector bracket" / Visser de "projector bracket" / Vite di "projector bracket" / Parafuso o "projector bracket"

7

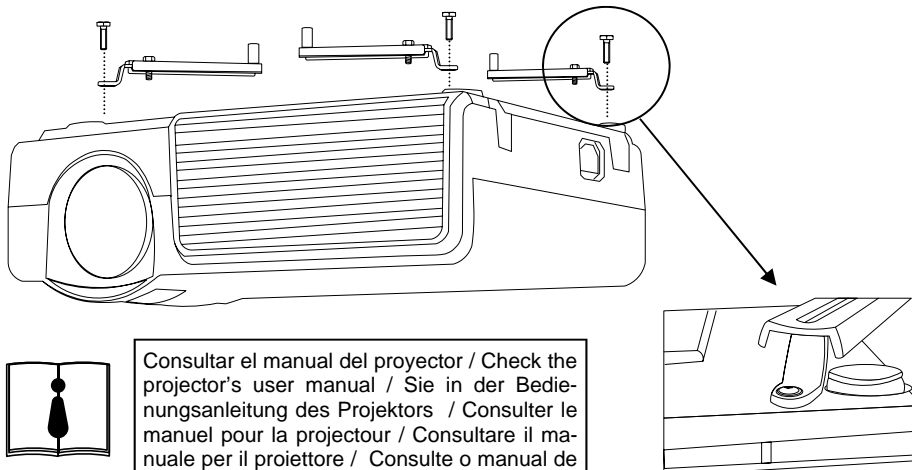

Consultar el manual del proyector / Check the projector's user manual / Sie in der Bedienungsanleitung des Projektors / Consulter le manuel pour la projecteur / Consultare il manuale per il proiettore / Consulte o manual de instruções o projetor

Instalación - installation - installation - installation - installazione - instalação

6 Sujetar el conjunto en el "videolift" / Hold the assembly in the "videolift" / Halten Sie die Montage in der "videolift" / Maintenez l'ensemble de la "videolift" / Tenere il montaggio del "videolift" / Segure a montagem do "videolift"

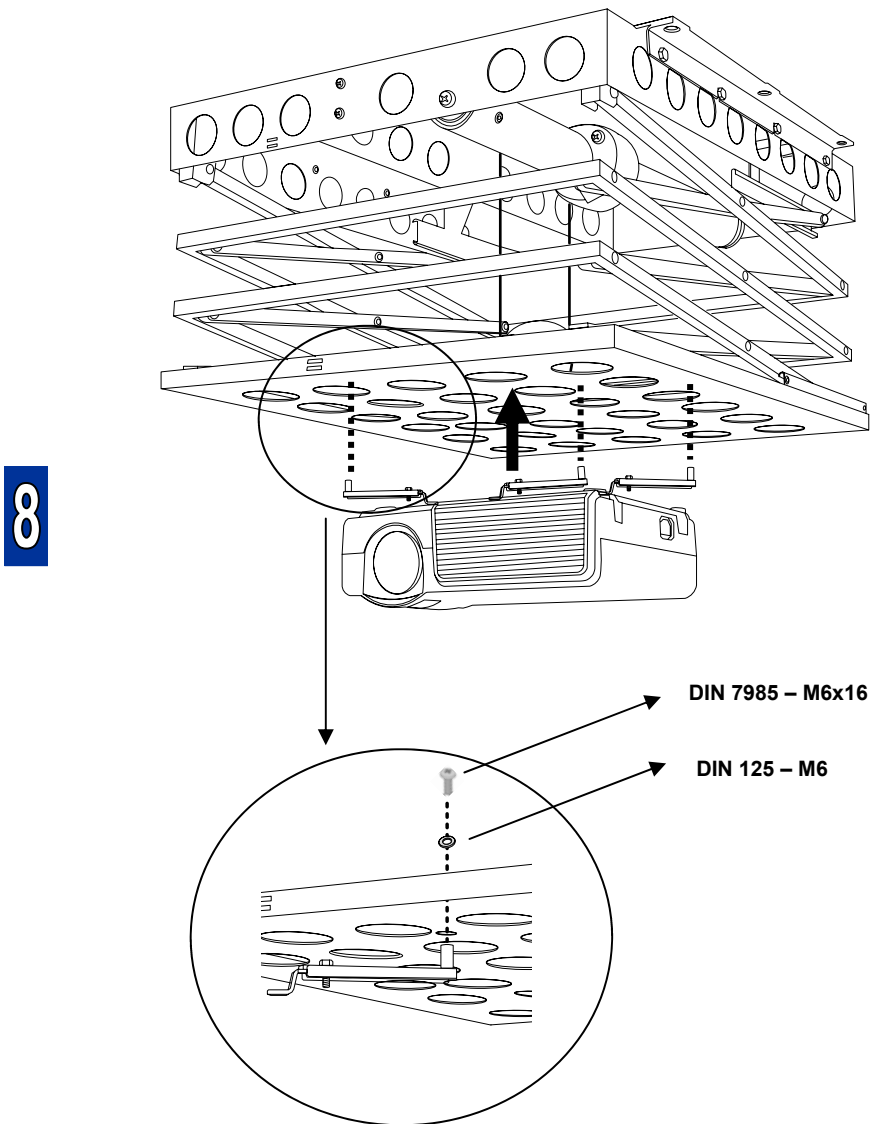

TRAULIFT Premium Series

7 Instalar las "column A" y corte / Install the "column A" and cut / Installieren Sie die "column A" und schneiden / Installation de la "columnne A" et de réduire / Installare la "Column A" e di ridurre / Instale o "column A" e corte

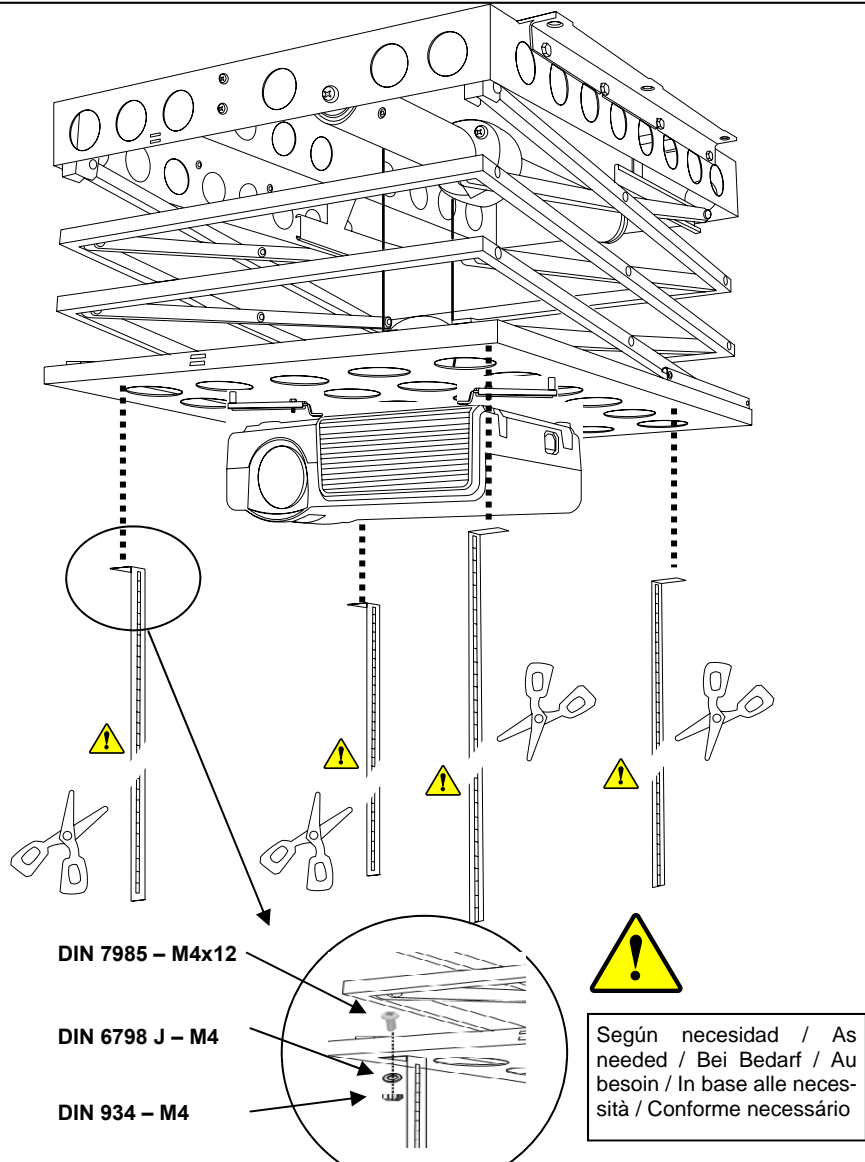

9

8 Instalar las "column B" y el "close cap" / Install the "column A" and "close cap" / Installieren Sie die "column B" und "close cap" / Installation de la "columnne B" et de "close cap" / Installare la "column B" e di "close cap" / Instale o "column B" e "close cap"

10

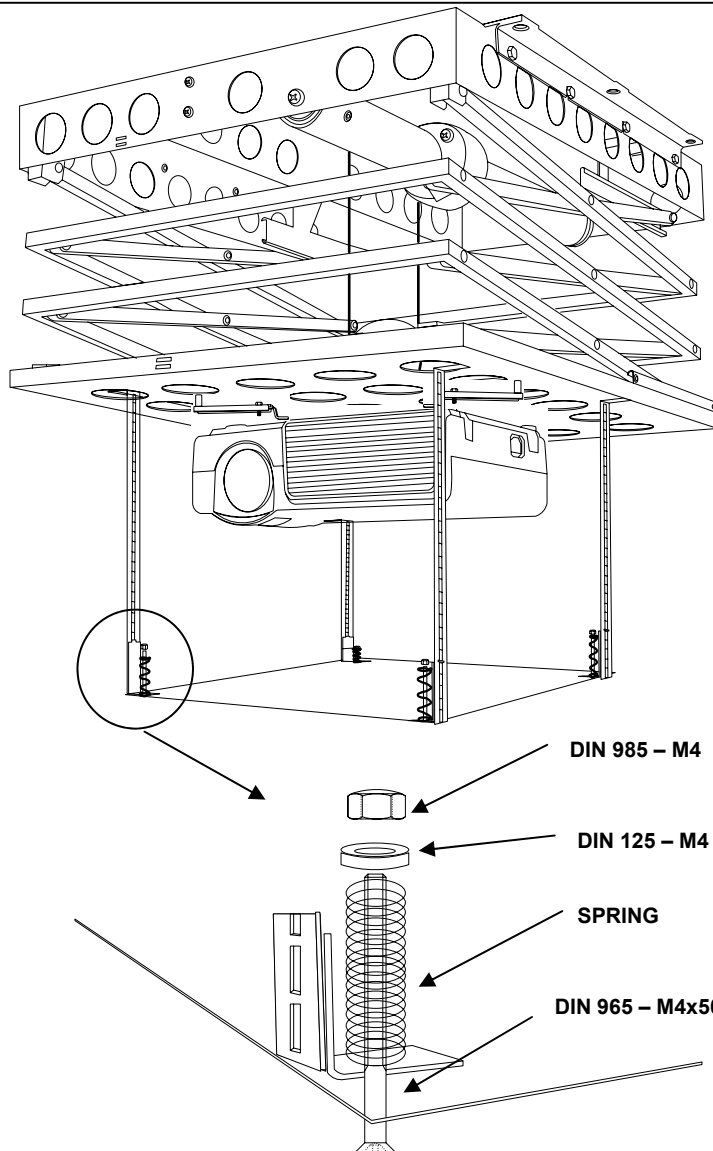

Instalación - installation - installation - installation - installazione - instalação

9 Instalar la tapa de cierre final / Install the end cap closure / Installieren Sie die Endkappe Schließung / Installer le capuchon de fermeture / Installare il tappo di chiusura della fine / Instale a tampa final encerramento

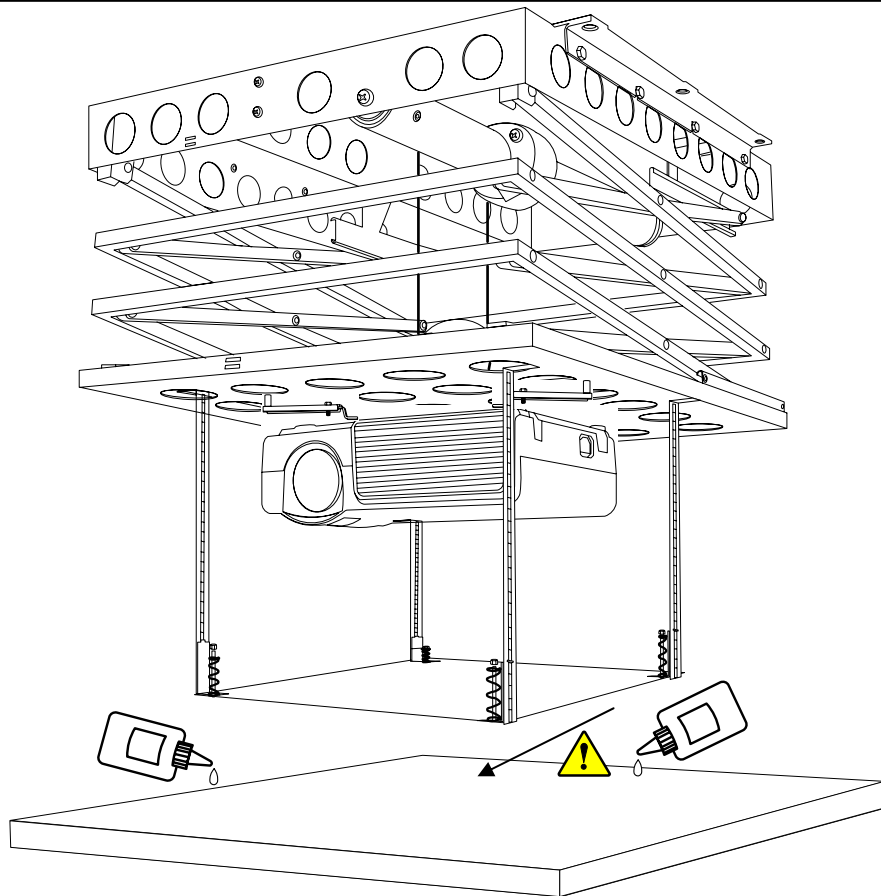

Pegar o atornillar según necesidad / Glue or screw as needed / Kleben oder Schrauben als notwendig / la colle ou de vis en tant que de besoin / colla vite o, in base alle necessità / Cola ou parafuso conforme necessário

TRAULIFT Premium Series

10 Conexión eléctrica / Electrical connection / Elektrischer Anschluss / Raccordement électrique / Collegamento elettrico / Ligaçao eléctrica

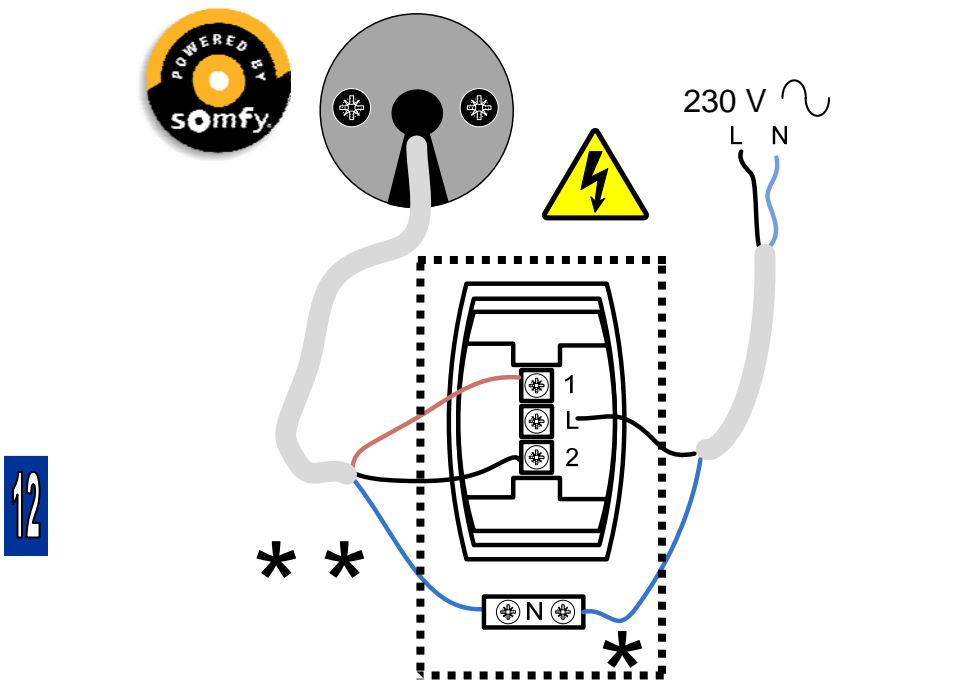

12

*	* *		
No suministrado Not supplied Nicht im Lieferumfang enthalten Non fourni Non in dotazione Não fornecido	Marrón ↑ Brown ↑ Braun ↑ Marron ↑ Marrone ↑ Marrom ↑	Negro ↓ Black ↓ Schwarz ↓ Noir ↓ Nero ↓ Preto ↓	Azul Neutro Blue Neutral Blau Neutral Beu Neutre Blu Neutro Azul Neutro

11 Ajustar subida y bajada / Adjust up and down / Passen Sie auf und ab / Réglez en haut et en bas / Regolare su e giù / Ajuste para cima e para baixo

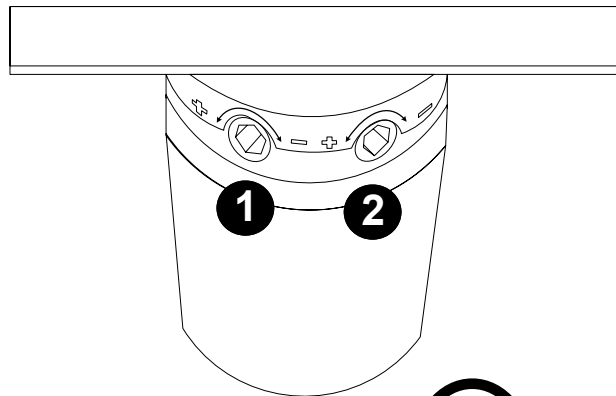

1

Regulación del límite superior
Up limit adjustment
Obere Endlange einstelle
Paramétrage du fin de course haut
Regolazione del fine corsa alto
Regulação do ponto alto do fim de curso

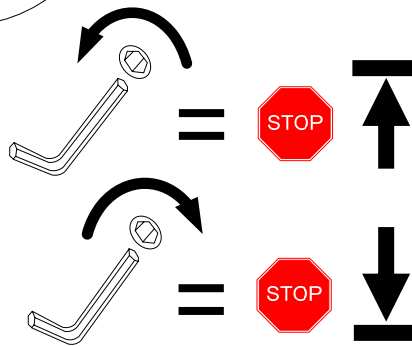

13

2

Regulación del límite inferior
Down limit adjustment
Untere Endlange einstelle
Paramétrage du fin de course bas
Regolazione del fine corsa basso
Regulação do ponto baixo do fim de

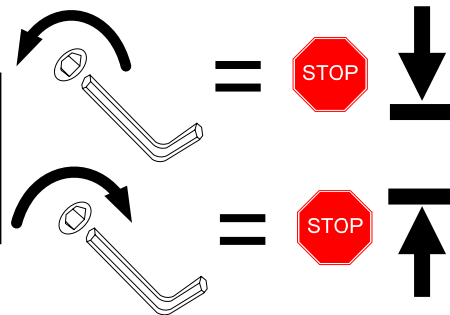

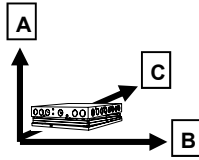

VL-100PR	A 110 mm B 400 mm C 470 mm
VL-200PR	A 140 mm B 400 mm C 470 mm



VL-100PR	Max. +50°C Min. -10°C
VL-200PR	Max. +50°C Min. -10°C

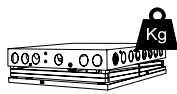

VL-100PR	10,4 Kg
VL-200PR	12,2 Kg

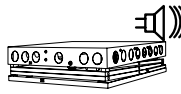

VL-100PR	< 50 Db
VL-200PR	< 50 Db



VL-100PR	45 sg
VL-200PR	90 sg

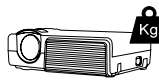

VL-100PR	19 Kg Max
VL-200PR	19 Kg Max



VL-100PR	180 sg
VL-200PR	180 sg



VL-100PR	230 V 50 Hz 100 W
VL-200PR	230 V 50 Hz 100 W

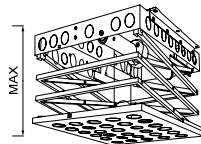

VL-100PR	95 cm
VL-200PR	195 cm

Esquema eléctrico
Electrical diagram
Elektro-Diagramm
Schéma électrique
Schema elettrico
Elétrica diagrama.

230-240 V ~

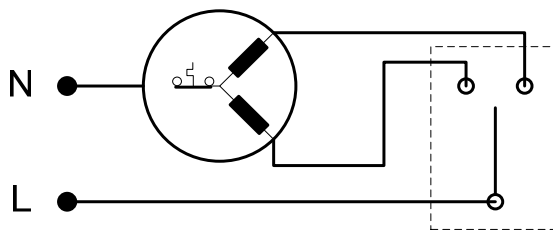

TRAULIFT Premium Series